

# B O M B A R D I E R

**Course Length**  
**15 Days (120 Hours)**

## **Bombardier BD-100-1A10 (Honeywell AS907) Aircraft**

### **B1 Theoretical Maintenance**

UAE GCAA  
Approval Number:



UAE.CAR 147.31

Other GLOBALJET courses available for  
your Bombardier BD-100-1A10  
(Honeywell AS907) type aircraft:

**Other GCAA Approved Courses:**  
*Bombardier BD-100-1A10 (Honeywell AS907)  
B1 Practical*

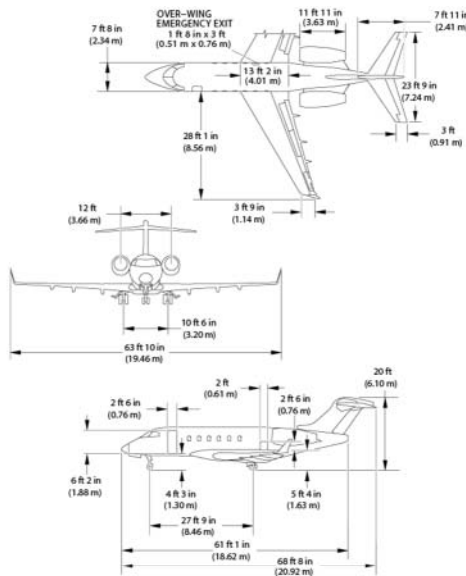

This GCAA B1 Theoretical maintenance training course meets all current UAE GCAA approval requirements for the Bombardier BD-100-1A10 (Honeywell AS907) aircraft type. The course covers all applicable ATA chapters to address aircraft systems' theory, operation, inspection, and servicing.

The theoretical course employs an interactive approach with instruction to the student. Upon successful completion, this class will certify aviation technicians for work on Bombardier BD-100-1A10 (Honeywell AS907) type aircraft.

**For more information on your Bombardier BD-100-1A10  
(Honeywell AS907) please contact:**

[Sales@globaljetservices.com](mailto:Sales@globaljetservices.com)

30 Tower Lane →  
Avon, CT → 06001

Tel (860) 651-6090 → Fax (860) 651-3618  
[globaljetservices.com](http://globaljetservices.com)

